

# Advantage Series

Wall to Tile Surround - Shower Channel and Grate

AWTSB



Creative Drain Solutions™

R3 - 01.07.2020

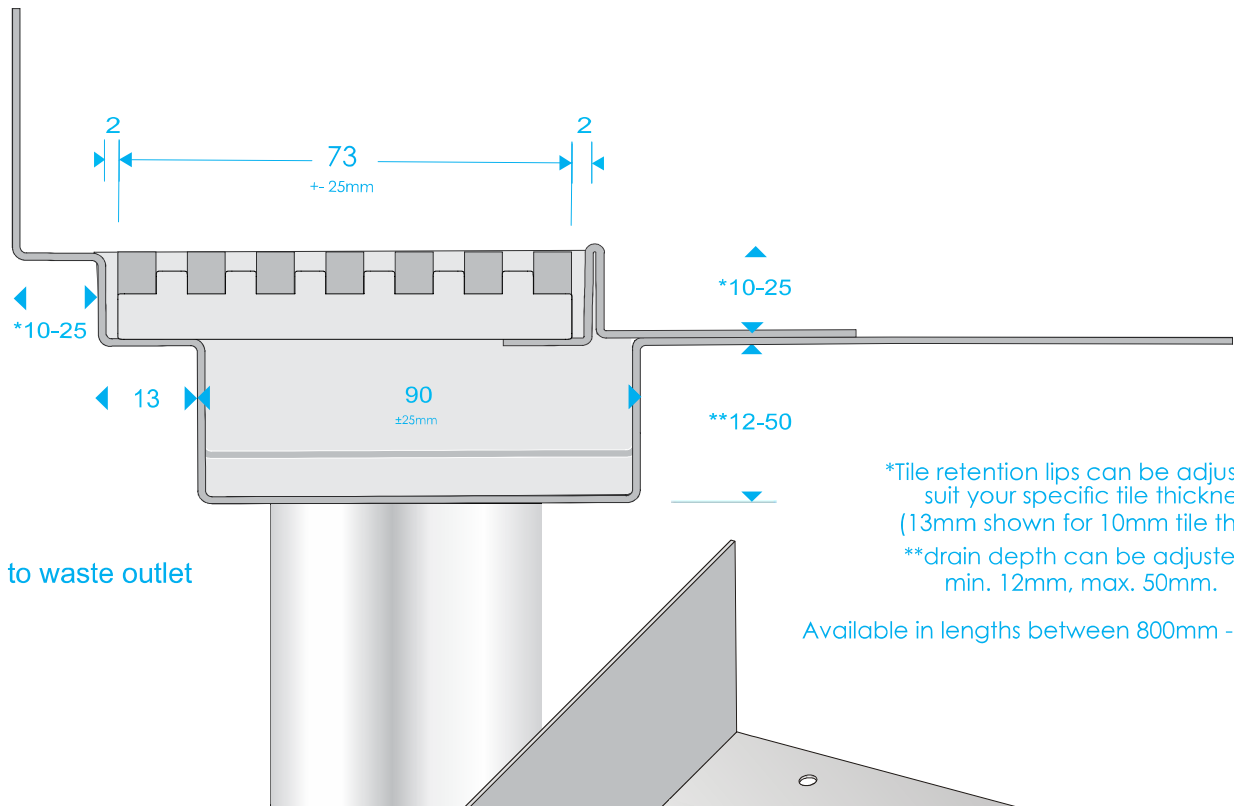

Built in fall to waste outlet

\*Tile retention lips can be adjusted to suit your specific tile thickness.  
(13mm shown for 10mm tile thickness)  
\*\*drain depth can be adjusted to suit, min. 12mm, max. 50mm.

Available in lengths between 800mm - 7000mm

Wide Waterproof Flanges built in

Punched Weep Holes - Eliminates Water Build Up

Custom Tile Retention Lip

Fixing Points

Custom Outlet to suit your requirements

- Manufactured exclusively from 316 Stainless Steel (Marine Grade)
- Durable, Corrosive Resistant, Tensile Strength.

All dimensions are in millimetres, +/- 3.  
Drains 1.2mm Stainless Steel

Disclaimer: These drawings are the intellectual property of Creative Drain Solutions. This information is indicative only. Creative Drain Solutions accepts no liability arising from the use of this information.