

# Graded Construction Board

Customised Drainage Solutions



Creative Drain Solutions™

Creative Drain Solutions Graded and Flat Construction Boards provide a cost effective alternative to conventional screed bases when creating fall on a balcony or bathroom floor.

## Features:

- ¿ Waterproof
- ¿ Extremely strong
- ¿ Easy to cut with a knife
- ¿ Even graded fall to lineal drains
- ¿ Sound insulation (20 decibels)
- ¿ Provides Thermal Heat insulation
- ¿ Capillary water absorption rate – Nil
- ¿ Light weighted approx. 3kg per M<sup>2</sup>
- ¿ Environmentally friendly, CFC and HCFC free
- ¿ High Compressive strength (withstand 30tm<sup>2</sup>)
- ¿ Heat deflection upwards with flat boards, suitable for use with hydronic heating systems
- ¿ Will reduce weight of screed floor areas by as much as 85%  
Eg. 1m<sup>2</sup> x 20mm Thick Sheet weighs 3kg.  
Sand and Cement screed 20mm weighs approx. 20kg.

## Exploded View

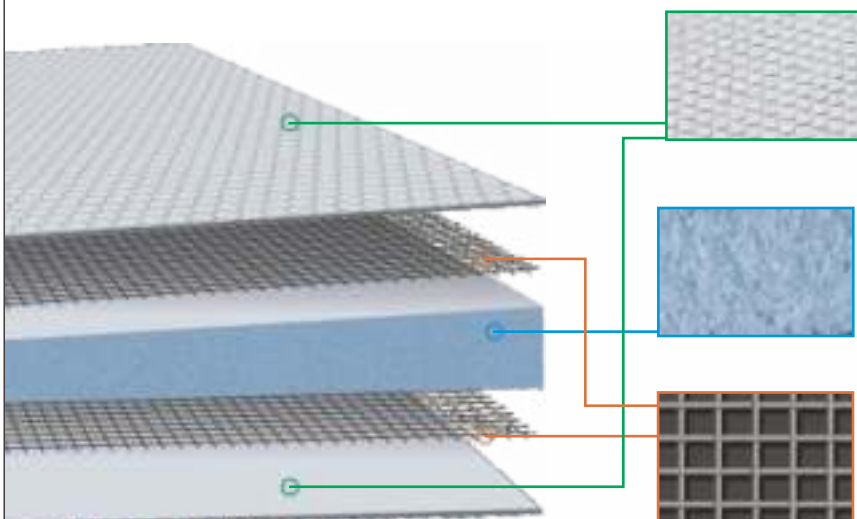

### Innovative “Honeycomb” cement surface.

Excellent surface characteristics for adhesion and waterproofing. Additional bond between the polymerised cement mortar and fibre glass mesh reinforcing.

### XPS Foam

Extruded polystyrene closed cell structure is lightweight, easy to cut and provides beneficial heat and noise installation.

### Fibre Glass Mesh

Embedded into the cement surfaces creating a mechanical resistance, waterproofing and bond to tile adhesive.

# Graded Construction Board

## Customised Drainage Solutions



Creative Drain Solutions™

Manufactured from extruded polystyrene, these innovative construction boards offer high waterproofing and insulation properties. It is covered on both sides with a fibre mesh (to provide mechanical resistance) and embedded in a polymerised cement mortar.

This combination provides to the system a mechanical resistance, water proofing and bond to tile adhesive.



Balconies

### Typical Balcony Installation

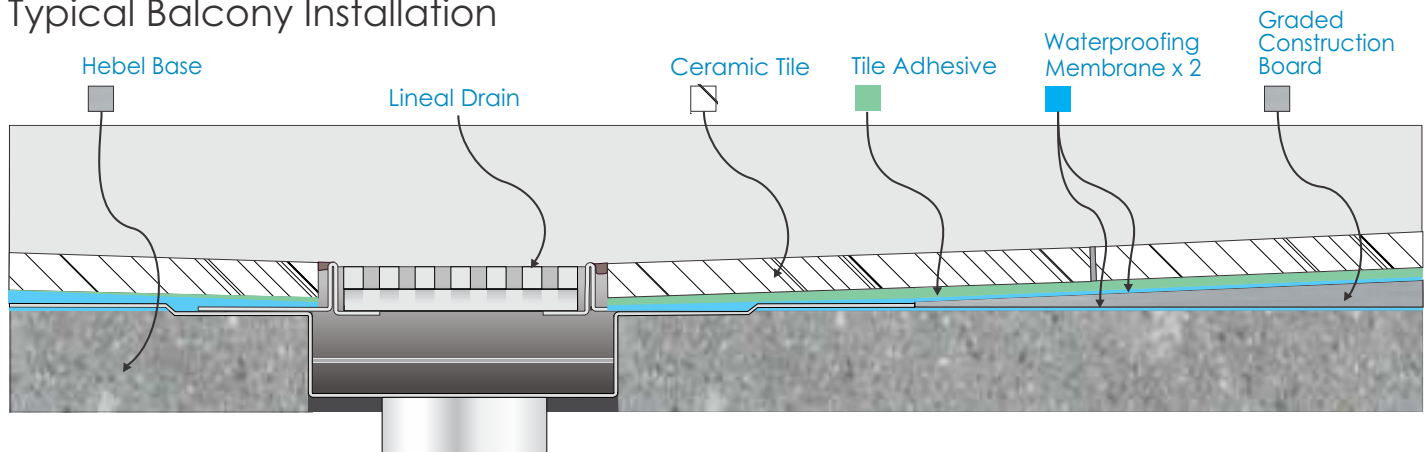

Sheet sizes available;

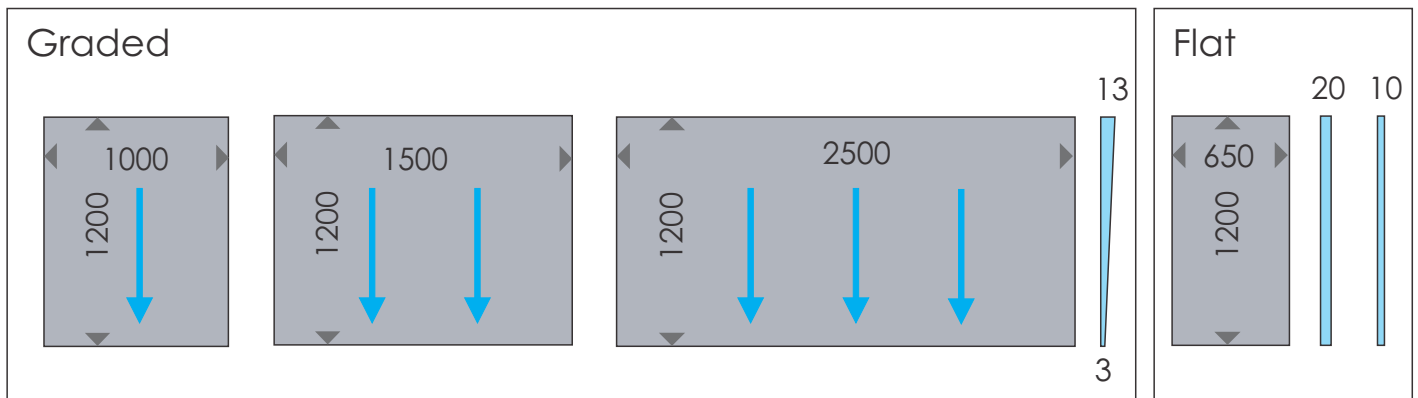

### Cross section



Disclaimer: These drawings are the intellectual property of Creative Drain Solutions. This information is indicative only. Creative Drain Solutions accepts no liability arising from the use of this information.

# Graded Construction Board

## Customised Drainage Solutions



Creative Drain Solutions™

With our Graded Construction Boards, you can easily build fall into your shower bases without having to screed; saving you time and money. Using adhesive, simply glue the boards down to your cement sheet base that has had a waterproofing membrane applied over it. A second layer of water proofing is then applied over the Graded Board to which the tiles or stone is glued.



### Typical Bathroom Installation

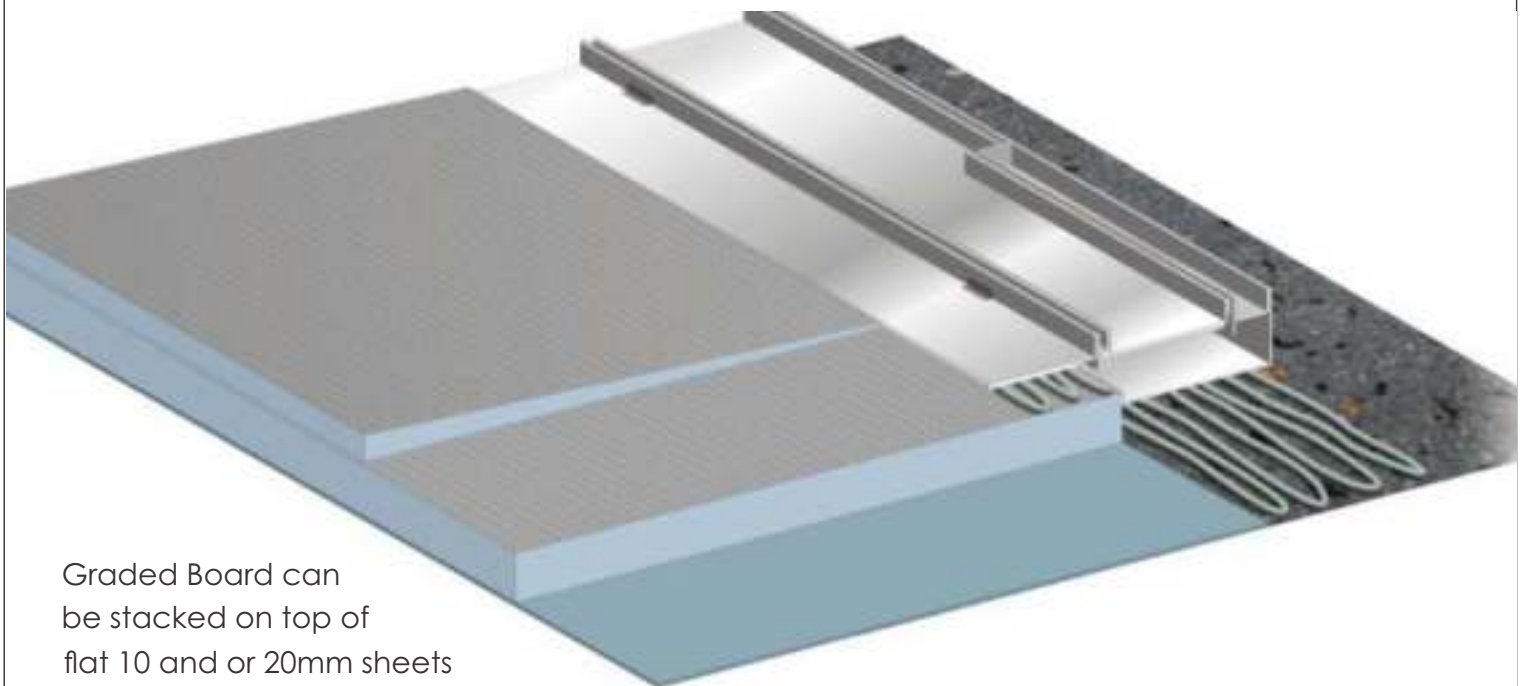
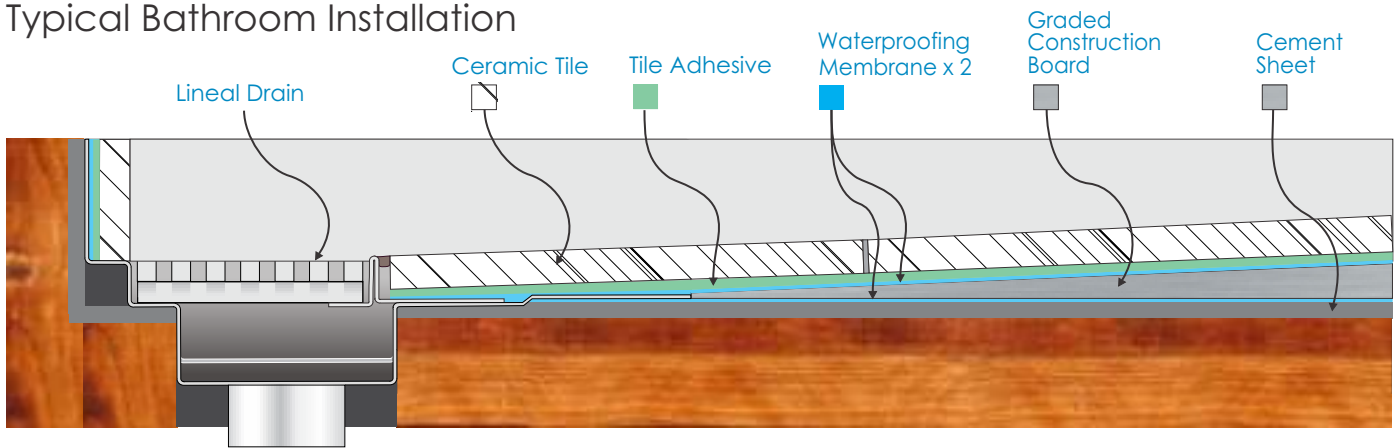

Graded Board can be stacked on top of flat 10 and or 20mm sheets to achieve a desirable height

Disclaimer: These drawings are the intellectual property of Creative Drain Solutions. This information is indicative only. Creative Drain Solutions accepts no liability arising from the use of this information.