

Advantage Series- Height Adjustable

Tile Surround - Tile Insert Tray

HATITS



Creative Drain Solutions™

R3 - 01.07.2020

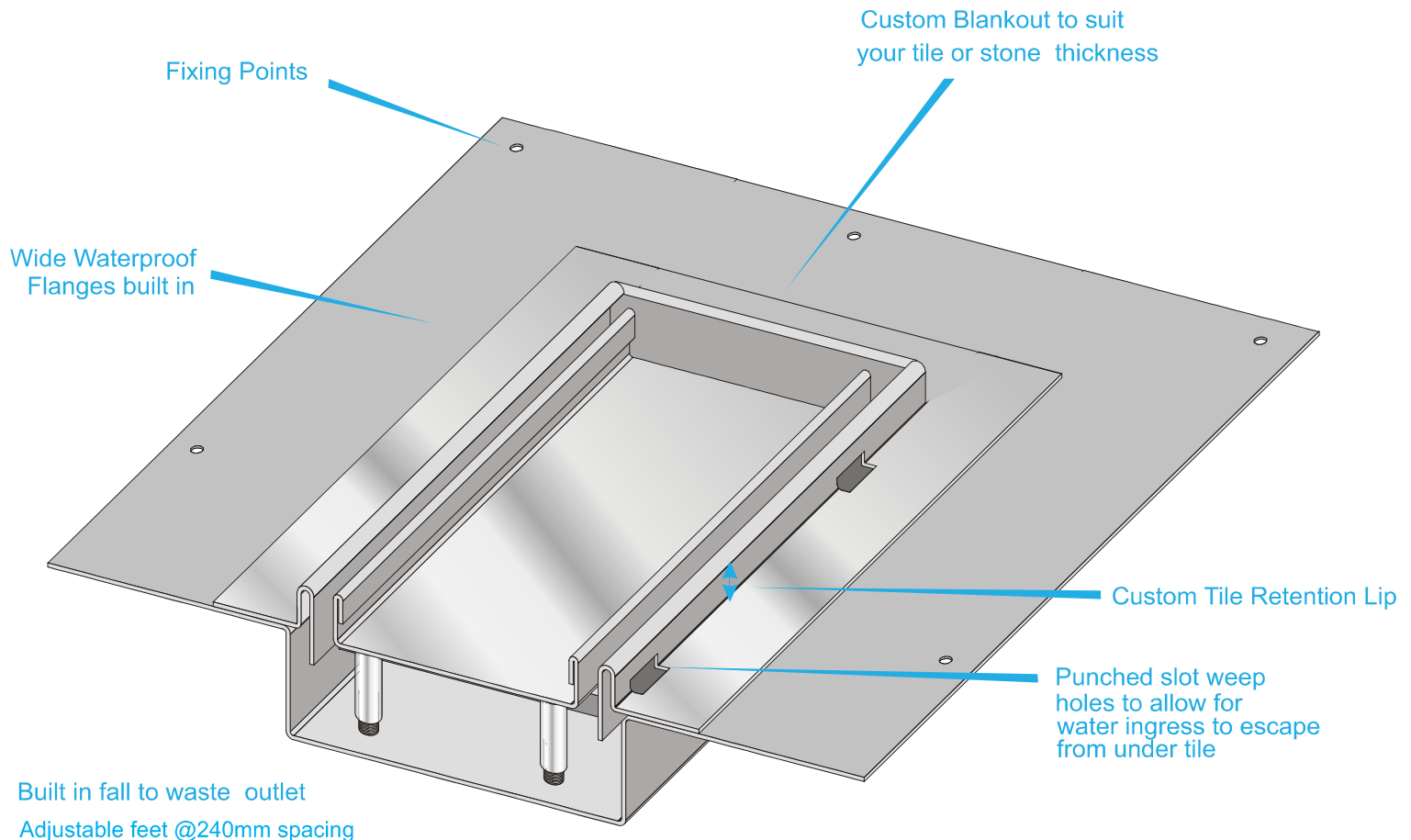
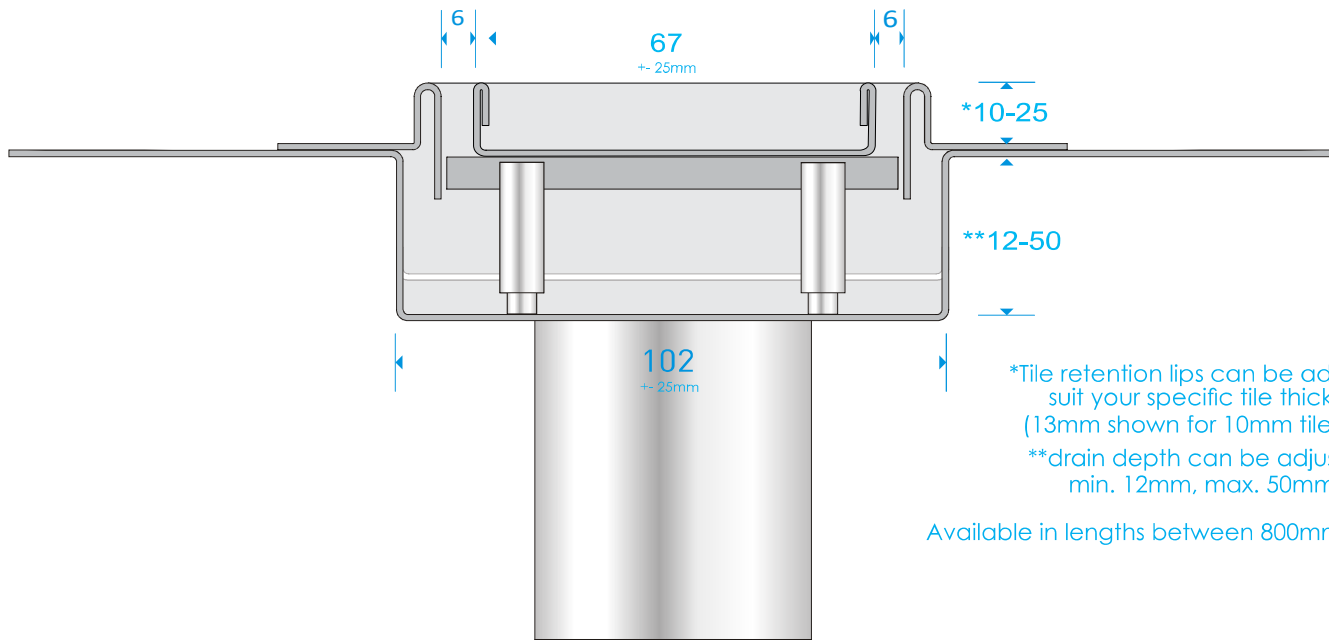

316

- Manufactured exclusively from 316 Stainless Steel (Marine Grade)
- Durable, Corrosive Resistant, Tensile Strength.

All dimensions are in millimetres, +/- 3.
Drains 1.2mm Stainless Steel

Disclaimer: These drawings are the intellectual property of Creative Drain Solutions. This information is indicative only. Creative Drain Solutions accepts no liability arising from the use of this information.

Creative Drain Solutions

Ph: (03) 9758 0588

creativedrainsolutions.com.au