

Advantage Series - Height Adjustable

Tile to Tile - Tile Insert Tray

HATITT



Creative Drain Solutions™

R3 - 01.07.2020

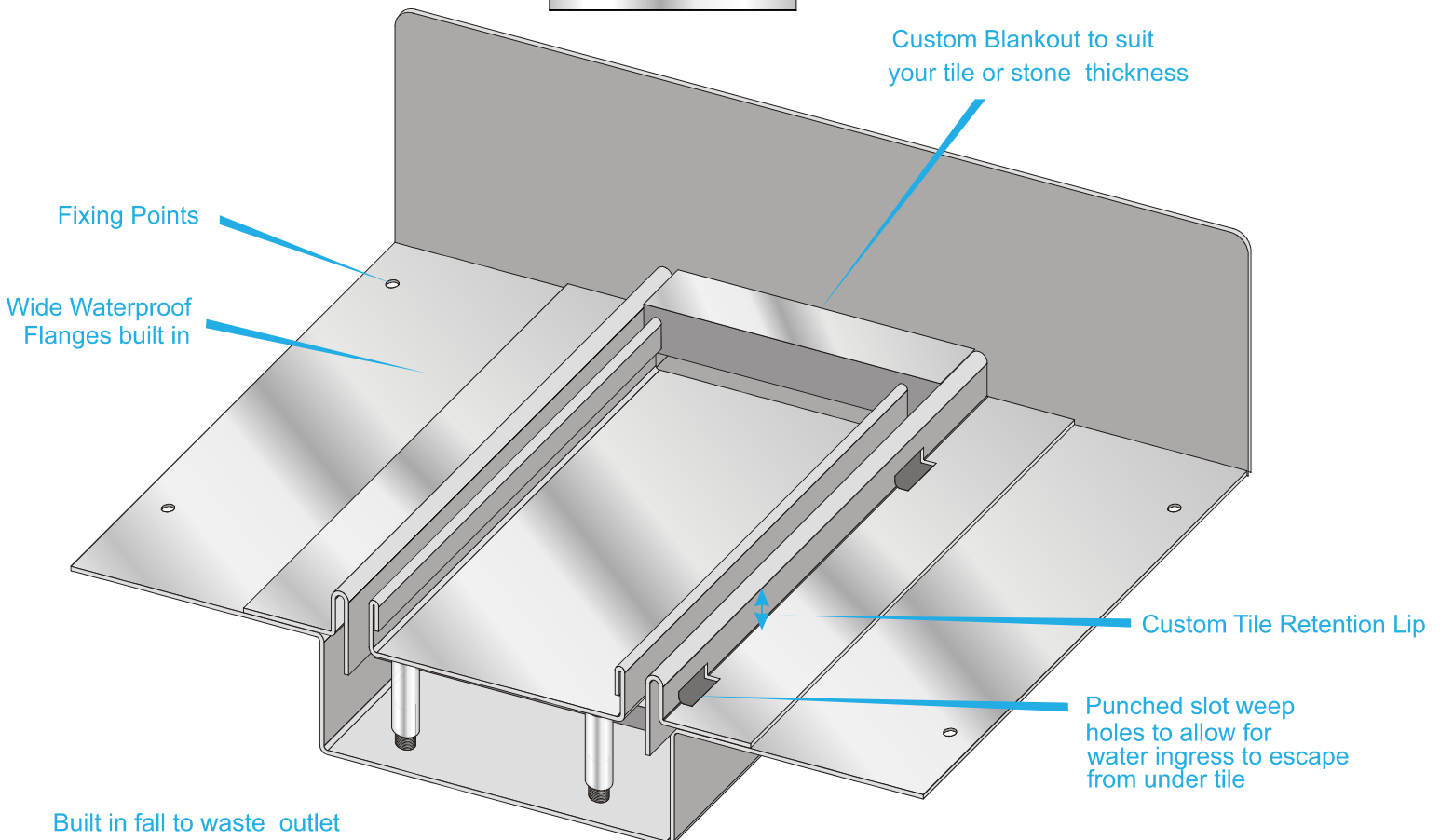
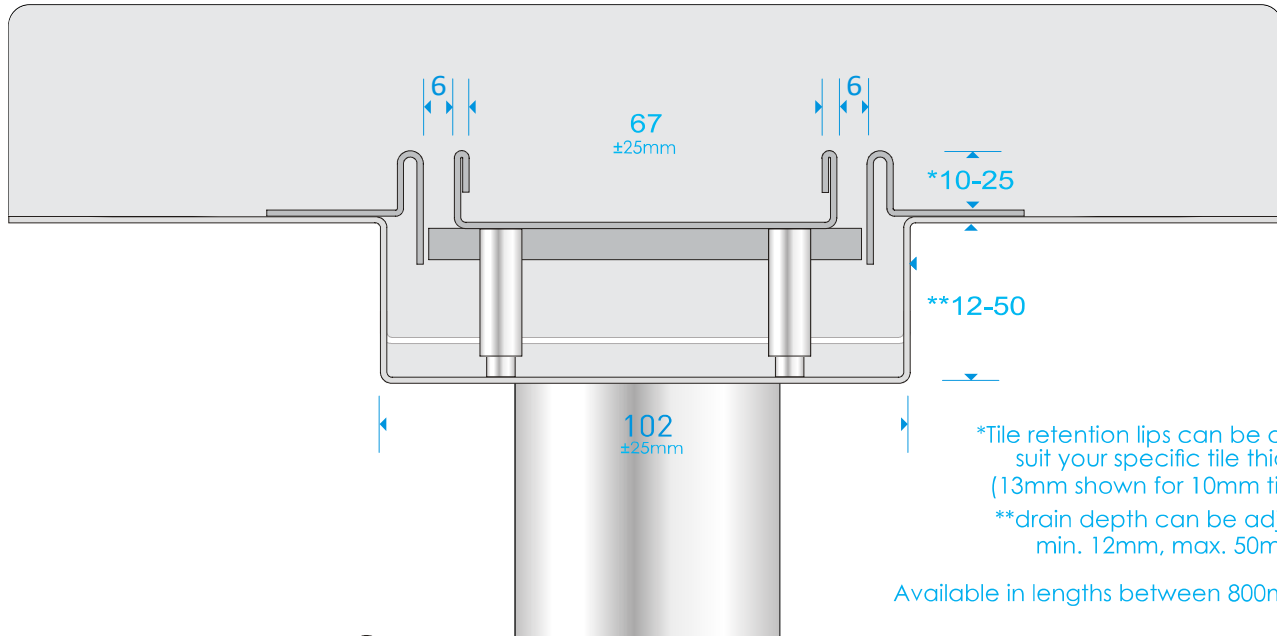

316

- Manufactured exclusively from 316 Stainless Steel (Marine Grade)
- Durable, Corrosive Resistant, Tensile Strength.

All dimensions are in millimetres, +/- 3.
Drains 1.2mm Stainless Steel

Disclaimer: These drawings are the intellectual property of Creative Drain Solutions. This information is indicative only. Creative Drain Solutions accepts no liability arising from the use of this information.