

Advantage Series

Tile to Tile - Inverted Tile Tray

ITTT



Creative Drain Solutions™

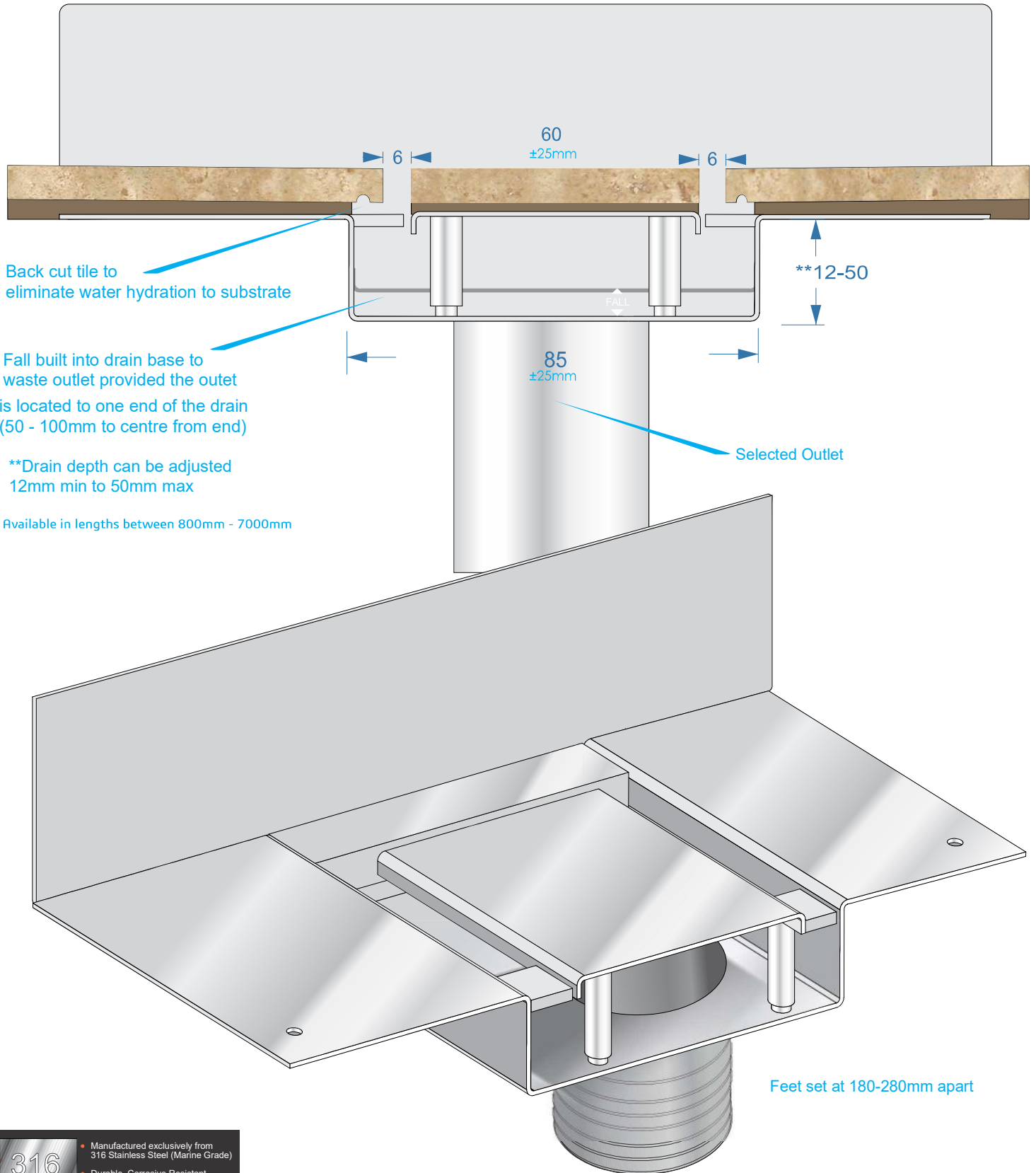

316

- Manufactured exclusively from 316 Stainless Steel (Marine Grade)
- Durable, Corrosive Resistant, Tensile Strength.

All dimensions are in millimetres, +/- 3.

Disclaimer: These drawings are the intellectual property of Creative Drain Solutions. This information is indicative only. Creative Drain Solutions accepts no liability arising from the use of this information.

Creative Drain Solutions

Ph: (03) 9758 0588

creativedrainsolutions.com.au