

Advantage Series

Wall to Tile - Inverted Tile Tray

ITWT



Creative Drain Solutions™

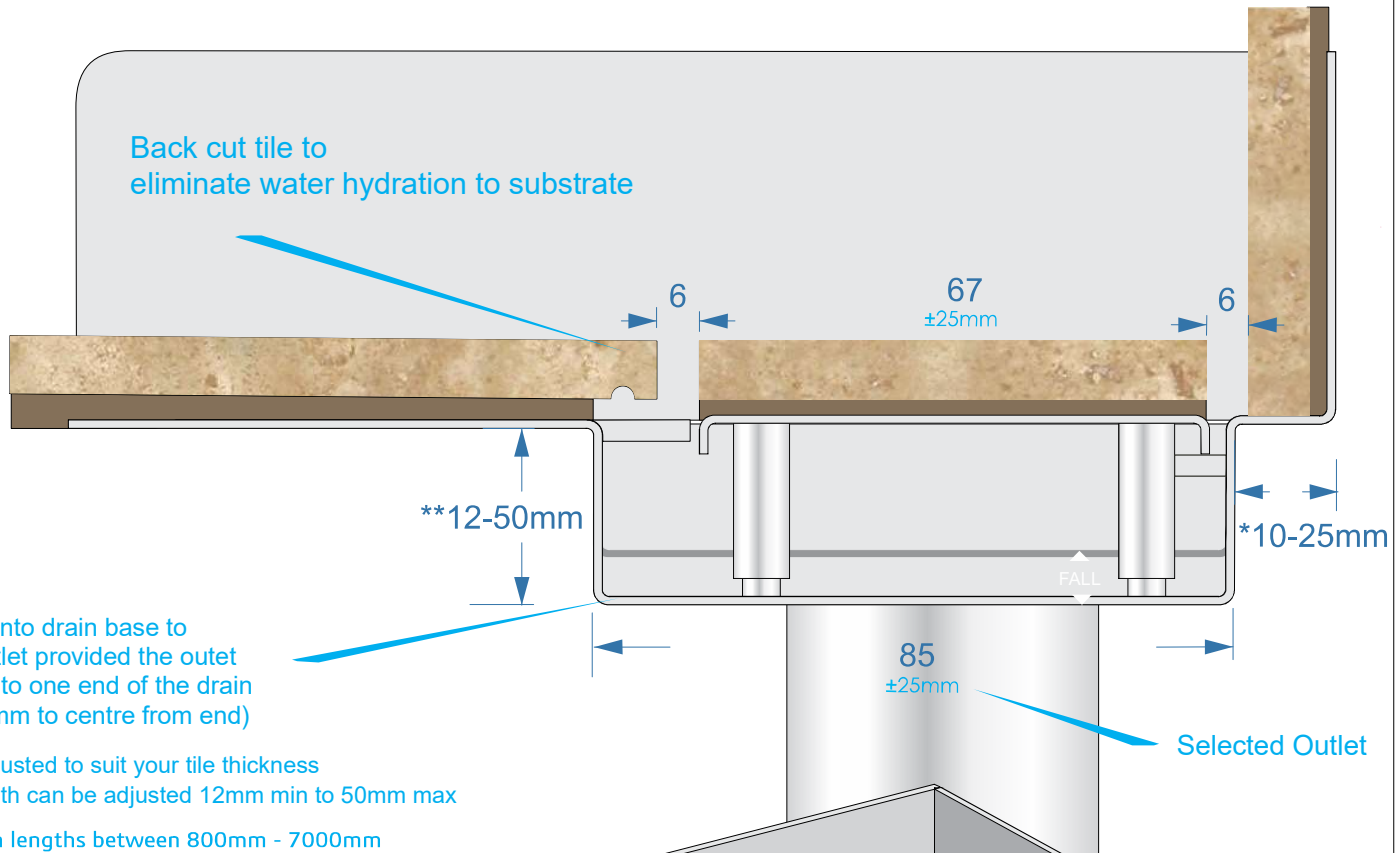

Fall built into drain base to waste outlet provided the outlet is located to one end of the drain (50 - 100mm to centre from end)

- *Can be adjusted to suit your tile thickness
- **Drain depth can be adjusted 12mm min to 50mm max

Available in lengths between 800mm - 7000mm

Feet set at 180-280mm apart

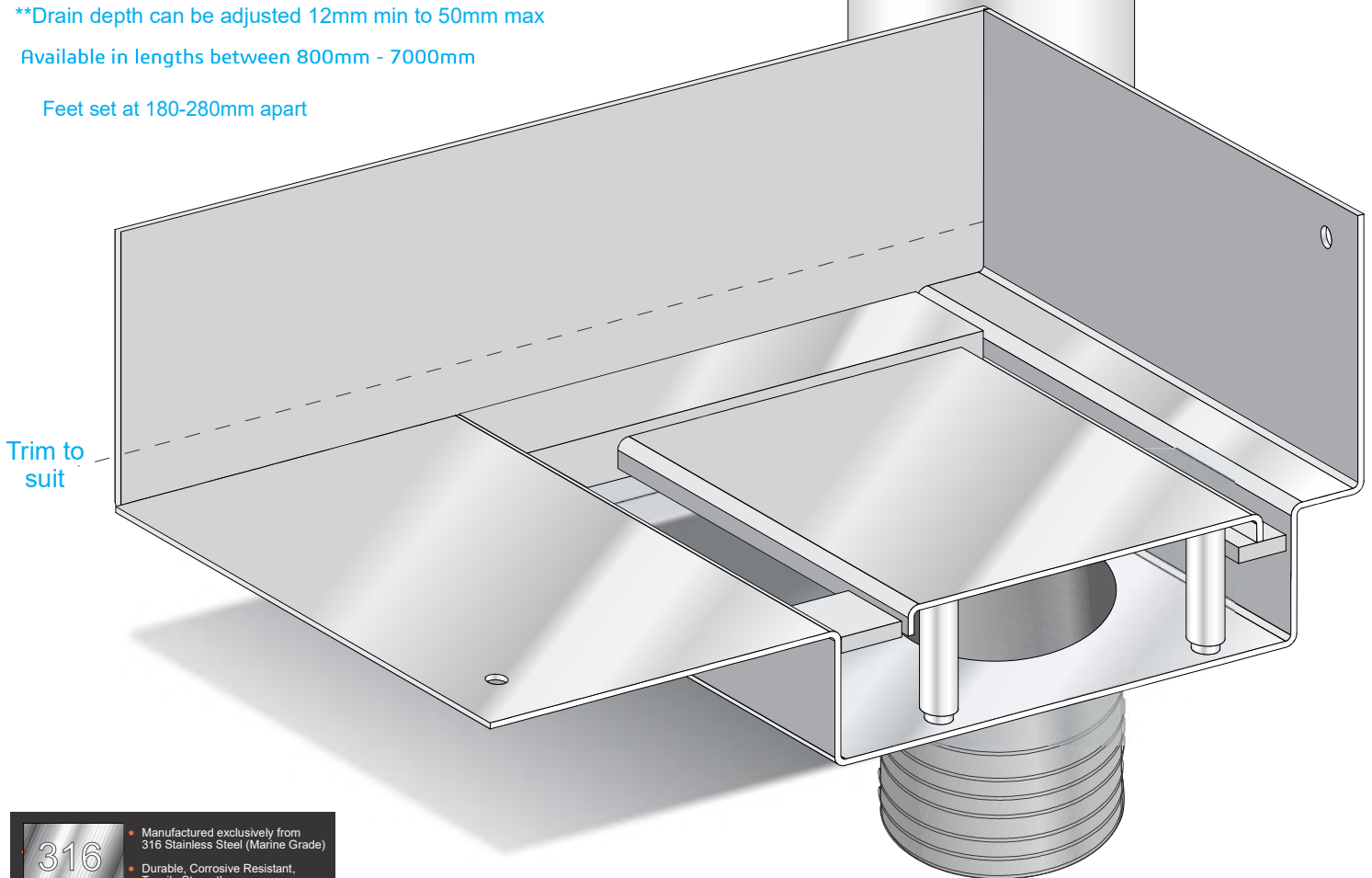

316

- Manufactured exclusively from 316 Stainless Steel (Marine Grade)
- Durable, Corrosive Resistant, Tensile Strength.

Disclaimer: These drawings are the intellectual property of Creative Drain Solutions. This information is indicative only. Creative Drain Solutions accepts no liability arising from the use of this information.