

Slot Cover Drain

Step by step installation guide

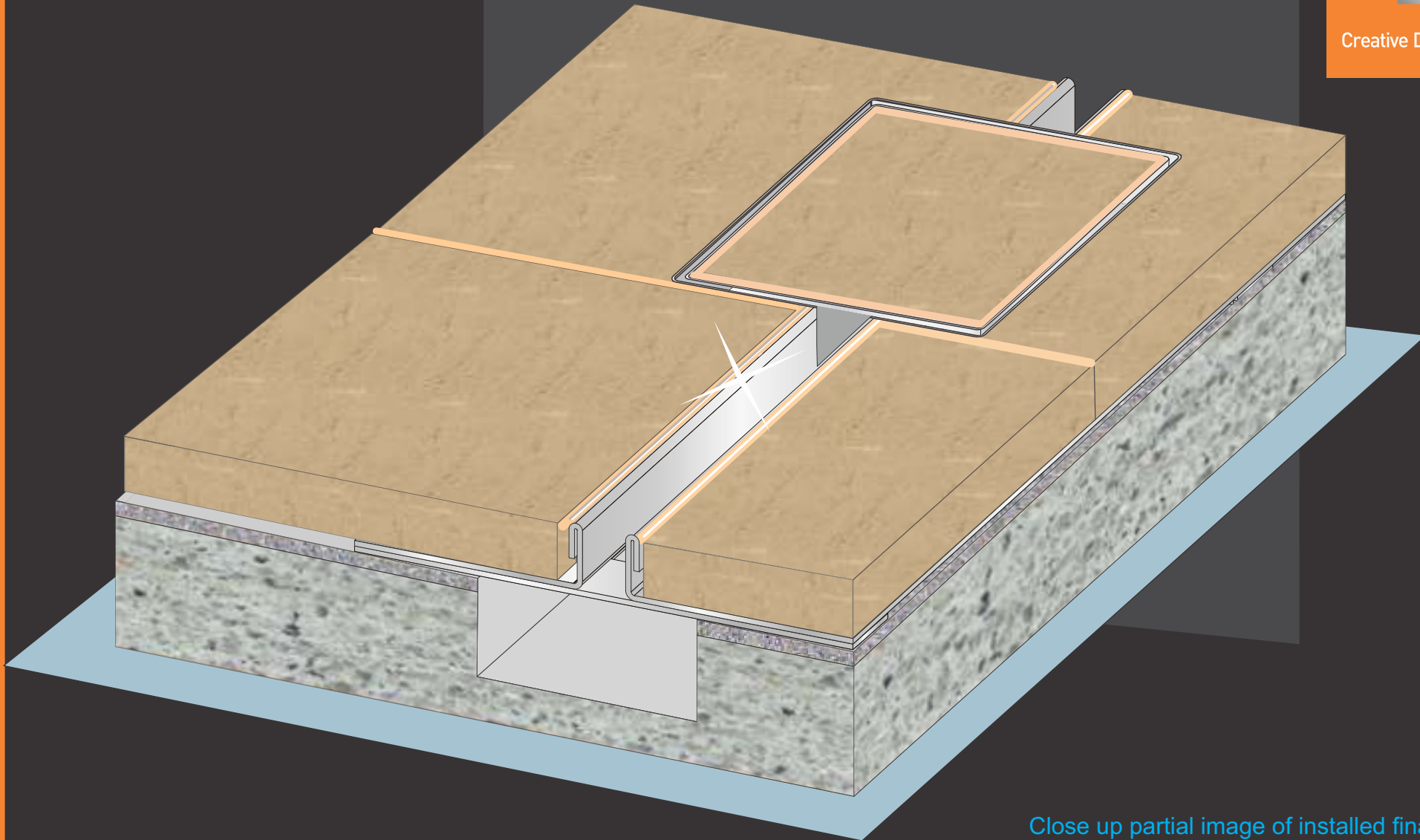

Creative Drain Solutions™



Close up partial image of installed final product

Disclaimer: These drawings are the intellectual property of Creative Drain Solutions. This information is indicative only. Creative Drain Solutions accepts no liability arising from the use of this information.

Creative Drain **Solutions**

Ph: (03) 9758 0588

createdrainsolutions.com.au

Installation Guide

These installation details are intended to be used as a guide only; we advise specific projects follow engineering advice and Australian Standards.



Creative Drain Solutions™

Required for installation

Tools

- Scotch brite
- Clean cloths
- Scraper
- Brush
- Paint brush or roller
- Caulking gun
- V-notch or Square notch trowel.
- MDF Spacer or alternate
- Roller tray
- Bucket

Materials

- Solvent or recommended cleaner
- Selected primer
- Waterproofing compound
- Adhesive / Sealer
- Mortar
- Selected pavers
- Color matched grout
- Color matched paver silicone

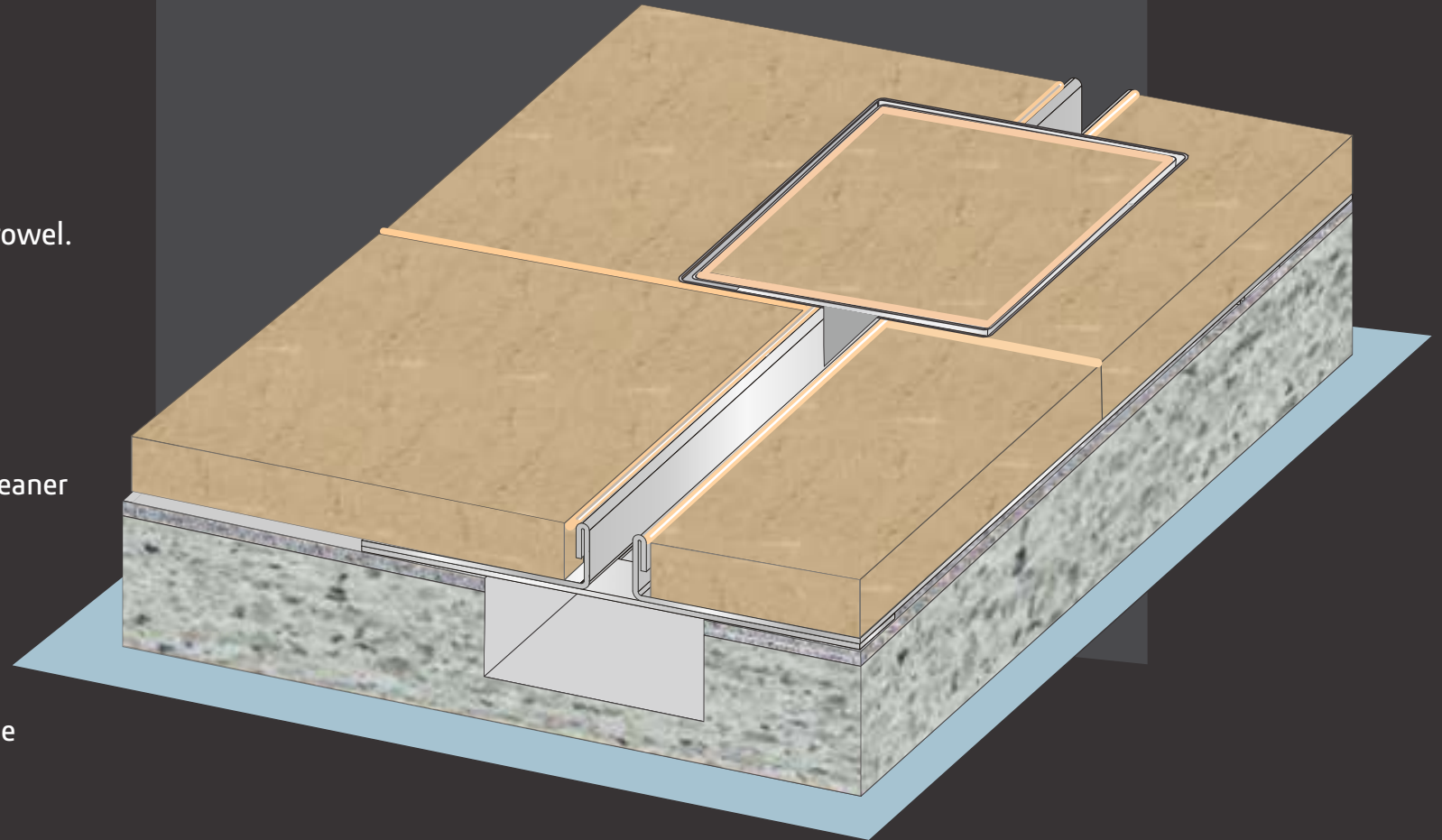

Disclaimer: These drawings are the intellectual property of Creative Drain Solutions. This information is indicative only. Creative Drain Solutions accepts no liability arising from the use of this information.

Creative Drain Solutions

Ph: (03) 9758 0588

creativedrainsolutions.com.au

Leave a rebate in the concrete
for your drain channel

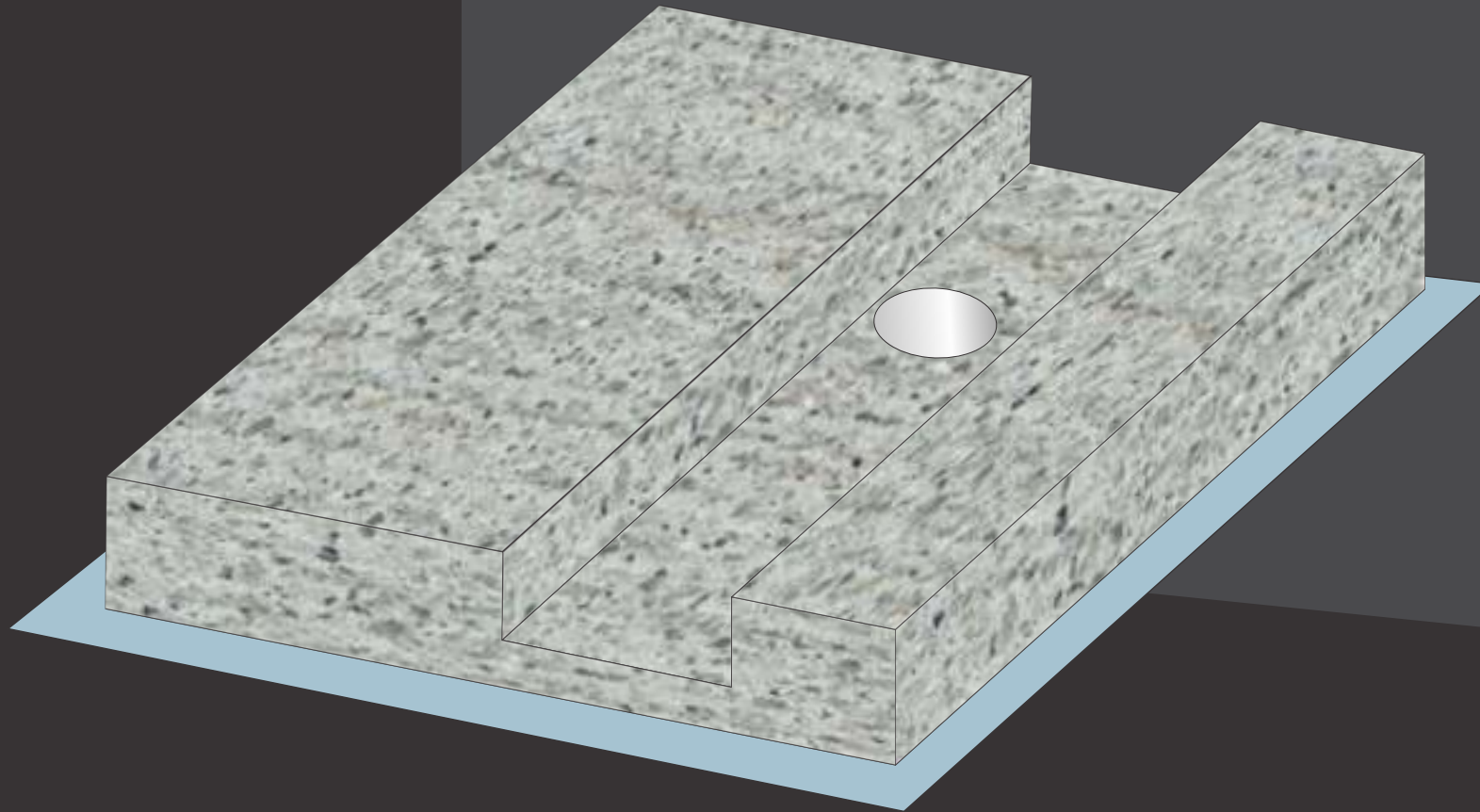

Creative Drain Solutions™

S T E P

1

These installation details are intended to be used as a guide only;
we advise specific projects follow engineering advice and Australian Standards.

Disclaimer: These drawings are the intellectual property of Creative Drain Solutions. This information is indicative only. Creative Drain Solutions accepts no liability arising from the use of this information.

Creative Drain **Solutions**

Ph: (03) 9758 0588

creativedrainsolutions.com.au

Screed either side of the rebate to create fall toward the channel.

Create fall in the drain toward the waste outlet.

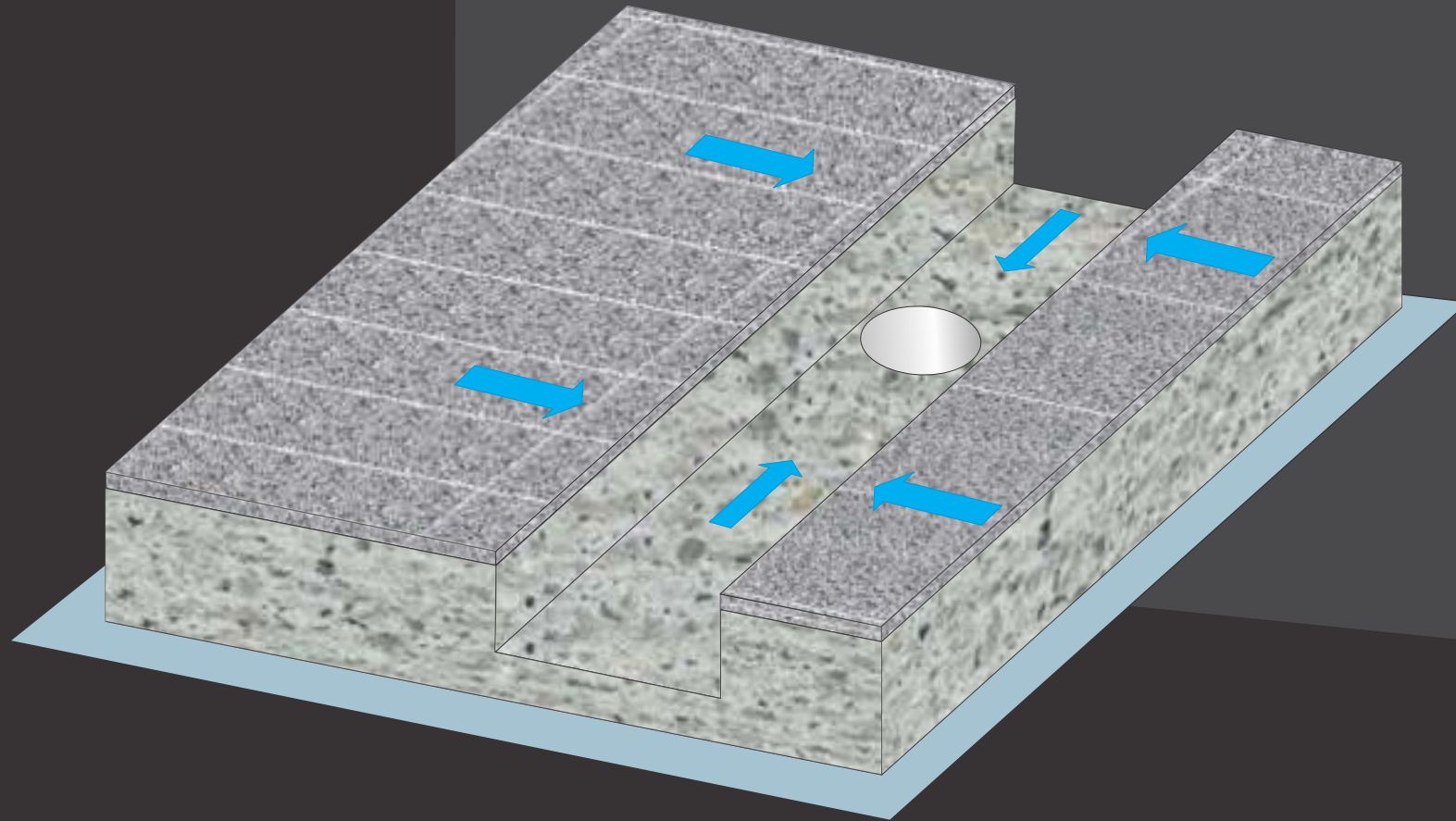

Creative Drain Solutions™

STEP

2

Disclaimer: These drawings are the intellectual property of Creative Drain Solutions. This information is indicative only. Creative Drain Solutions accepts no liability arising from the use of this information.

Creative Drain Solutions

Ph: (03) 9758 0588

creativedrainsolutions.com.au

Allow screed to dry then waterproof the top of the screed and inside the channel.

Allow waterproofing to dry.

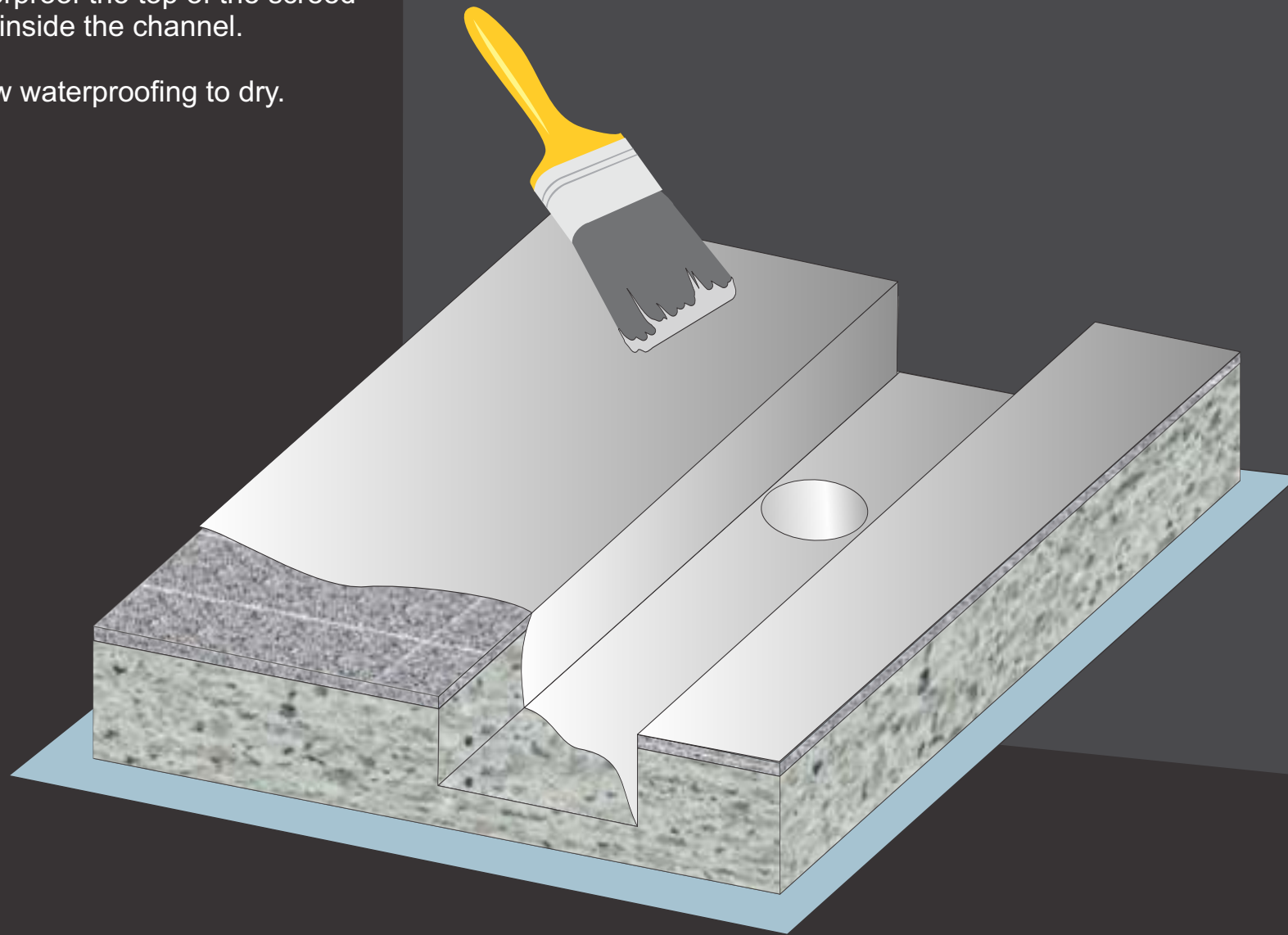

Creative Drain Solutions™

STEP
3

Disclaimer: These drawings are the intellectual property of Creative Drain Solutions. This information is indicative only. Creative Drain Solutions accepts no liability arising from the use of this information.

Creative Drain **Solutions**

Ph: (03) 9758 0588

createdrainsolutions.com.au

Caulk selected adhesive silicone where slot cover is to be placed. Blob between drain braces to allow any build up of water to drain freely into drain.

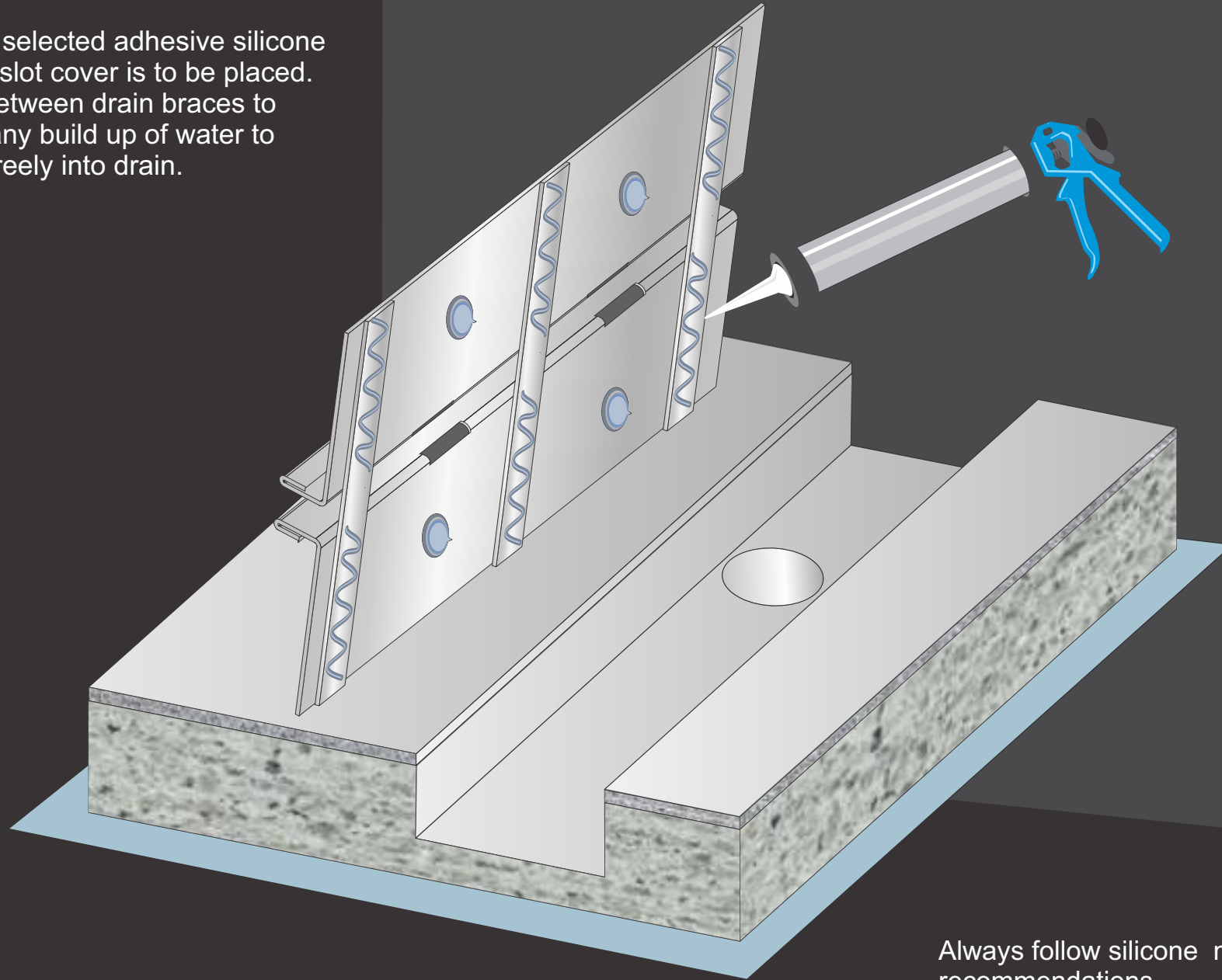

Creative Drain Solutions™

STEP

4

Always follow silicone manufacturers recommendations.

Disclaimer: These drawings are the intellectual property of Creative Drain Solutions. This information is indicative only. Creative Drain Solutions accepts no liability arising from the use of this information.

Creative Drain Solutions

Ph: (03) 9758 0588

createdrainsolutions.com.au

Place the slot down and press firmly and allow adhesive to dry.

Use the provided scouring pad to 'roughen' up the surface where the primer is to be applied using the scourer in a criss-cross motion over the flanges.

Wipe clear of dust and debris.

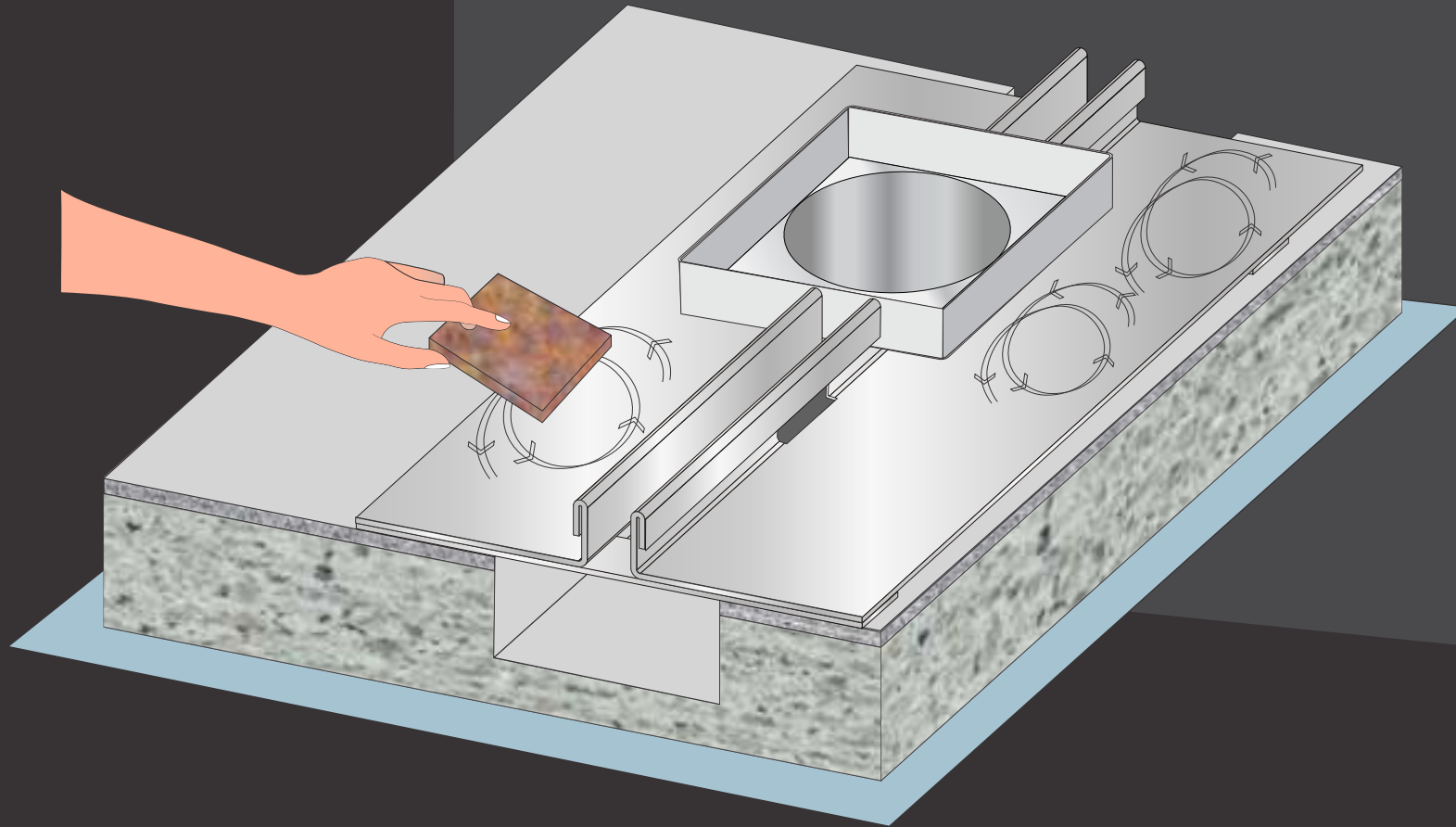

Creative Drain Solutions™

STEP

5

Paint on supplied primer to prepared flange faces to ensure that the waterproofing will adhere to the drain flanges.

Ensure the weep holes are kept free of primer and blockage.

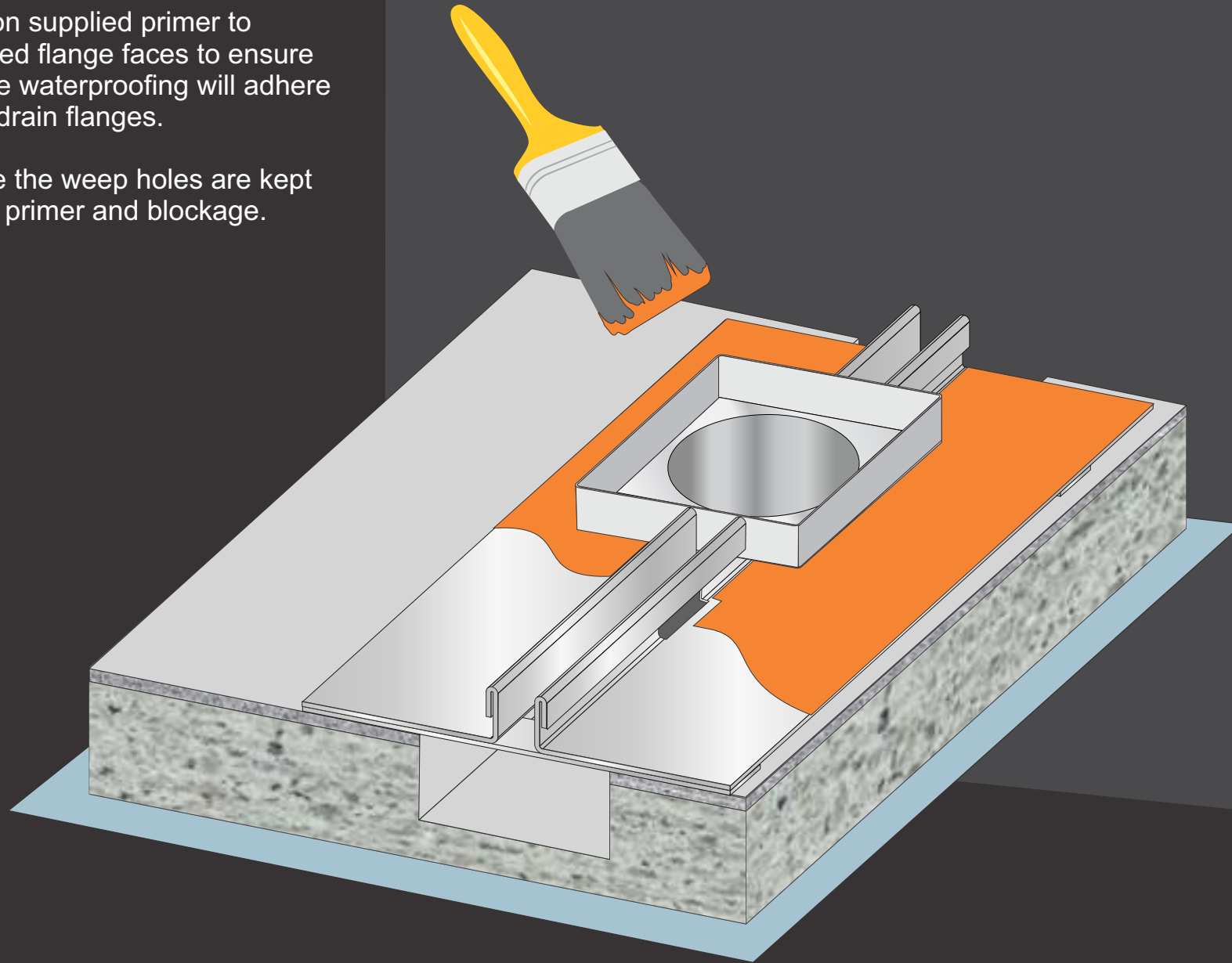

Creative Drain Solutions™

S T E P

6

Disclaimer: These drawings are the intellectual property of Creative Drain Solutions. This information is indicative only. Creative Drain Solutions accepts no liability arising from the use of this information.

Creative Drain **Solutions**

Ph: (03) 9758 0588

createdrainsolutions.com.au

Trowel mortar with a V-notch or Square notch trowel.
Follow manufacturers specifications.

Ensure weep holes are kept clear of mortar.

Use a removable spacer (MDF, plastic or similar) along the tile retention lip edge to space tiles away from edge.

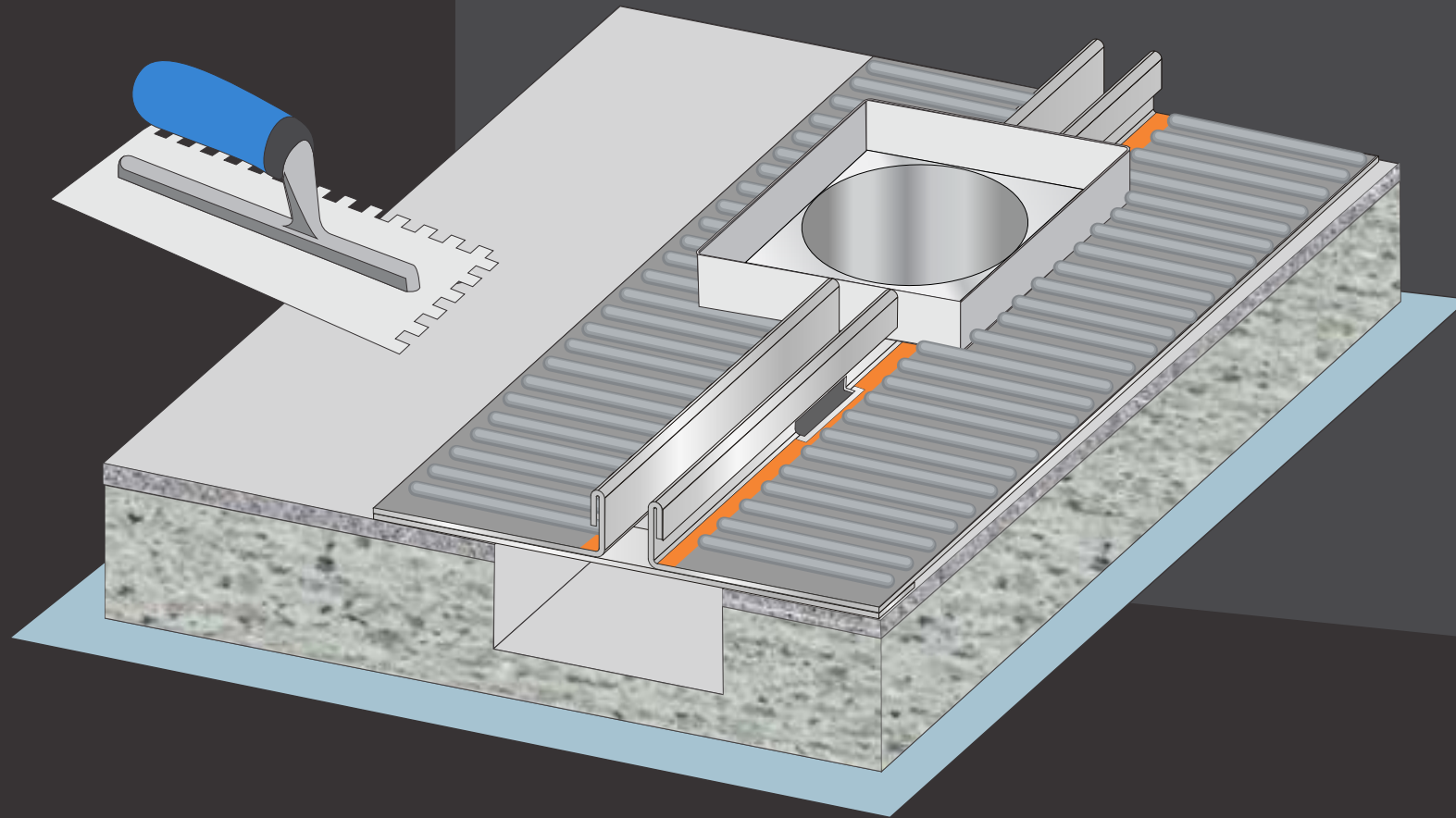

Creative Drain Solutions™

S T E P

Disclaimer: These drawings are the intellectual property of Creative Drain Solutions. This information is indicative only. Creative Drain Solutions accepts no liability arising from the use of this information.

Creative Drain **Solutions**

Ph: (03) 9758 0588

createdrainsolutions.com.au



Creative Drain Solutions™

STEP

9

IMPORTANT:

Ensure punched slots are clear of silicone or glue

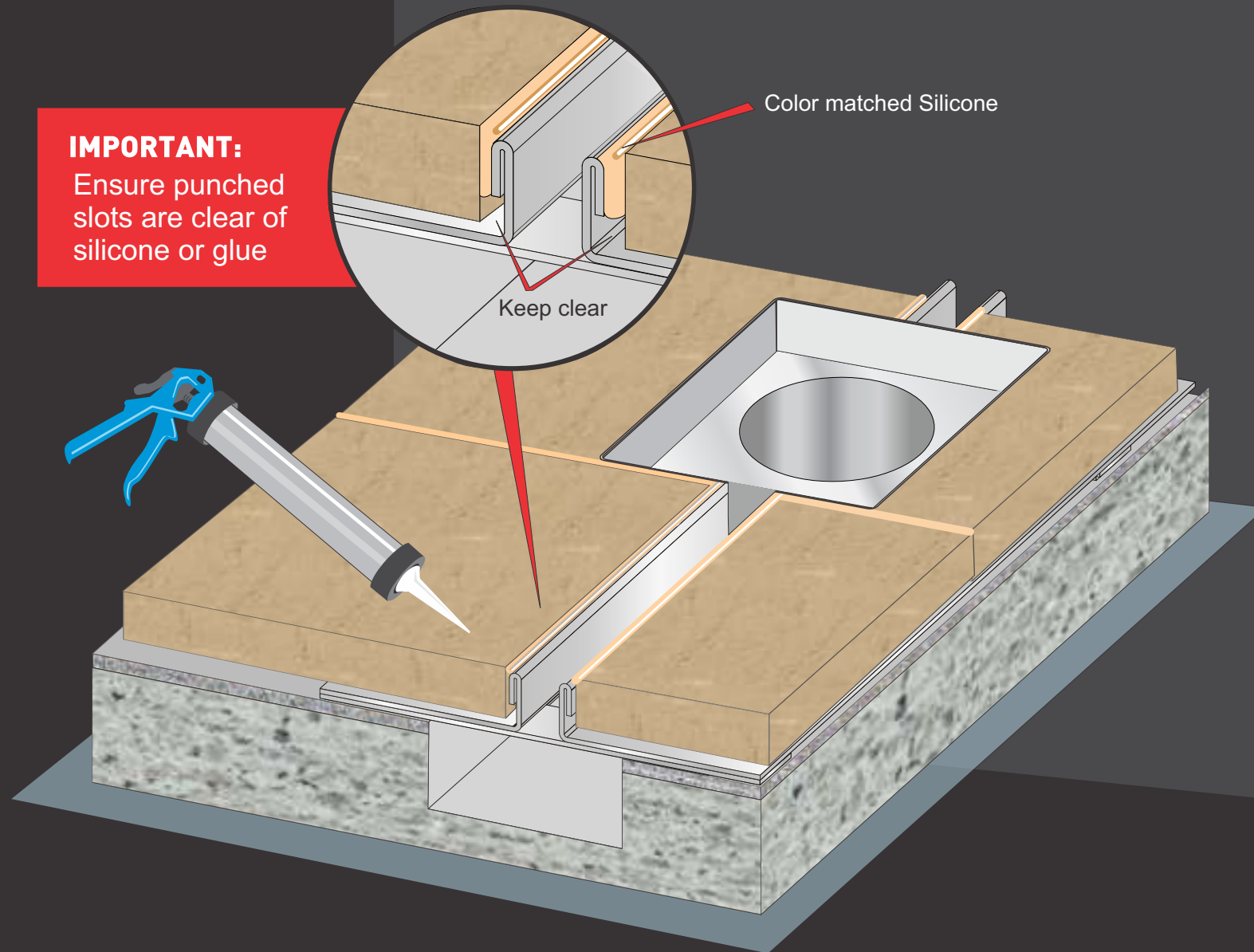

Disclaimer: These drawings are the intellectual property of Creative Drain Solutions. This information is indicative only. Creative Drain Solutions accepts no liability arising from the use of this information.

Creative Drain Solutions



Creative Drain Solutions™

S T E P

8

IMPORTANT:

Ensure there is a 3mm gap between the paver edge and the slot cover lip. Use a removable spacer to ensure consistent gap.

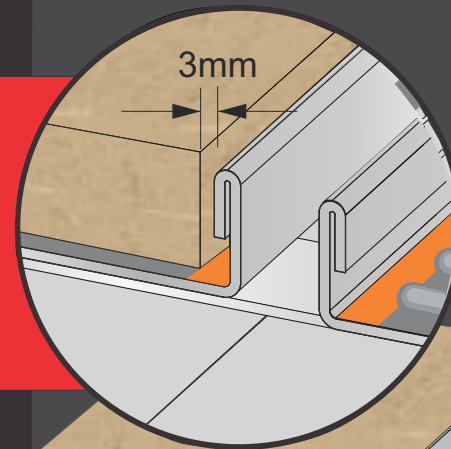

Packer /spacer

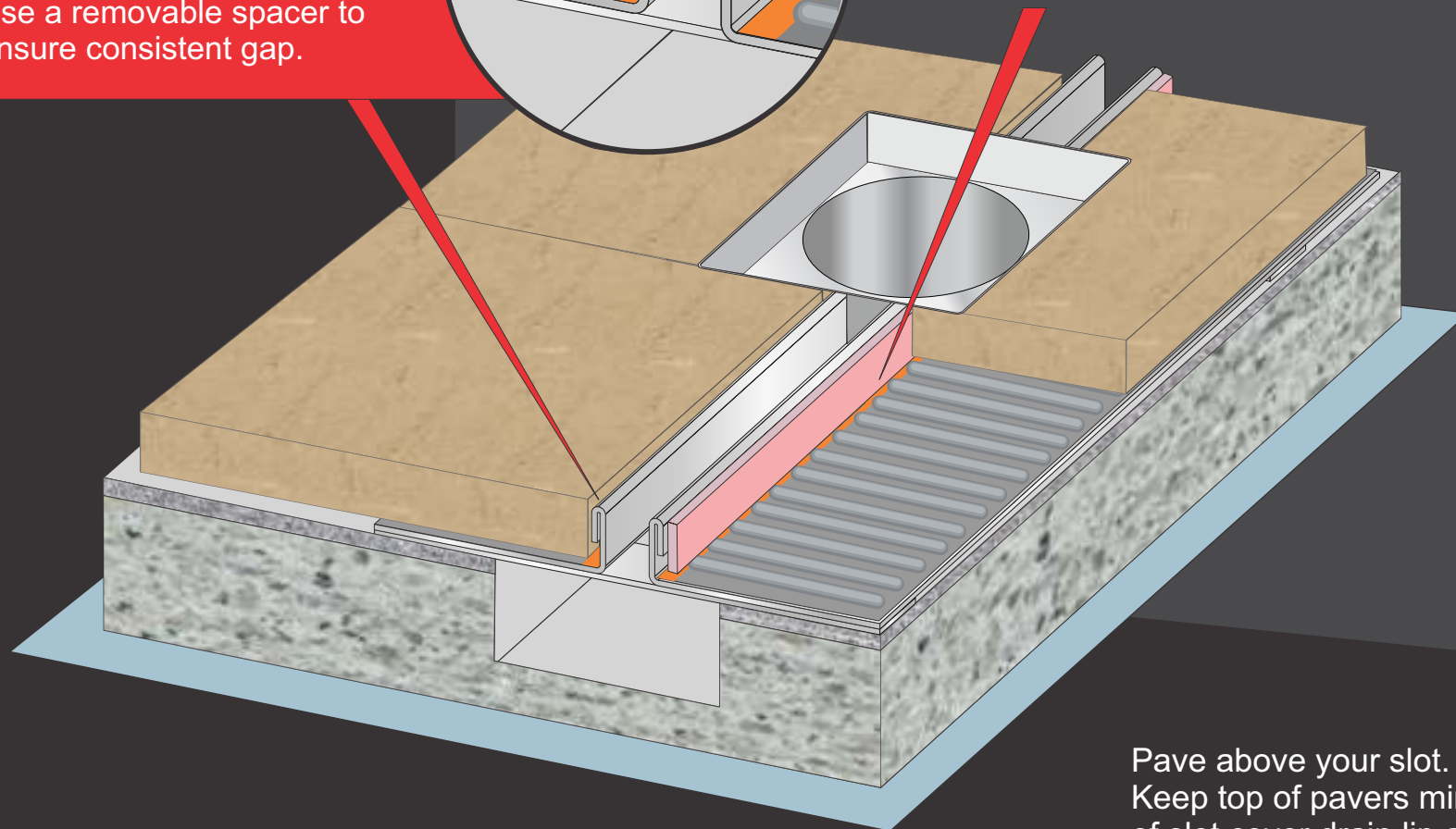

Pave above your slot.
Keep top of pavers min. 1mm above top
of slot cover drain lip and 3mm
horizontally from lip edge (using spacer).

Disclaimer: These drawings are the intellectual property of Creative Drain Solutions. This information is indicative only. Creative Drain Solutions accepts no liability arising from the use of this information.

Creative Drain Solutions

Ph: (03) 9758 0588

createdrainsolutions.com.au

Fit off removable Tile Insert Tray.

Lift out and clear any blockages in the drain regularly.

The drain may be cleaned by using a high pressure washer along the drain length and removing any debris.

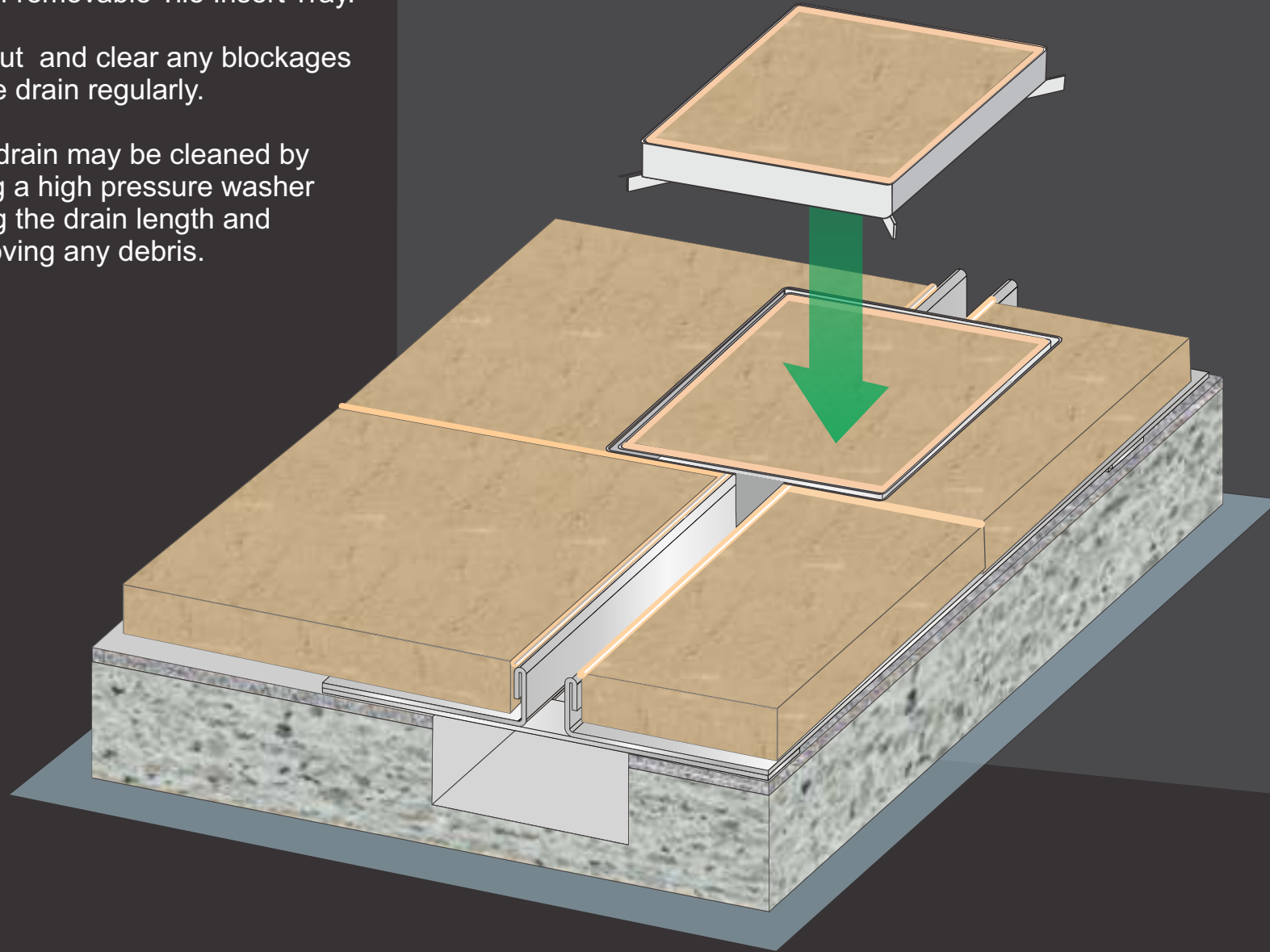

Creative Drain Solutions™

STEP

10