

# Advantage Series

## Tile to Tile - Tile Insert Tray with Central Glass

TITT - CG



Creative Drain Solutions™

R3 - 01.07.2020

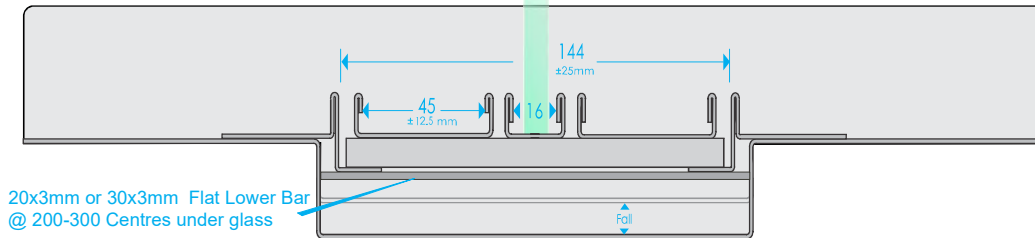

\*Tile retention lips can be adjusted to suit your specific tile thickness.  
(13mm shown for 10mm tile thickness)

\*\*drain depth can be adjusted to suit, min. 12mm, max. 50mm.

Available in lengths between 800mm - 7000mm

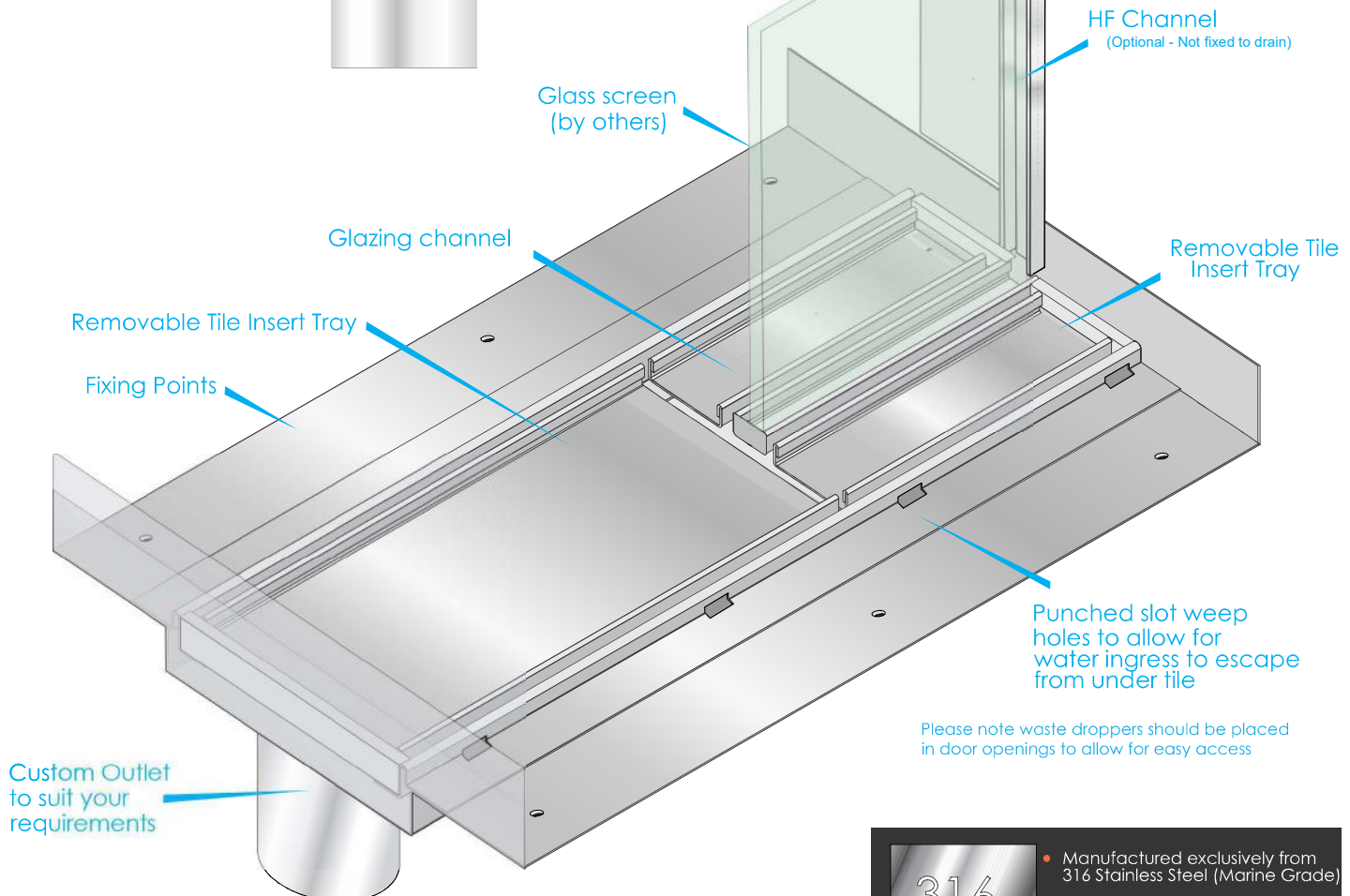
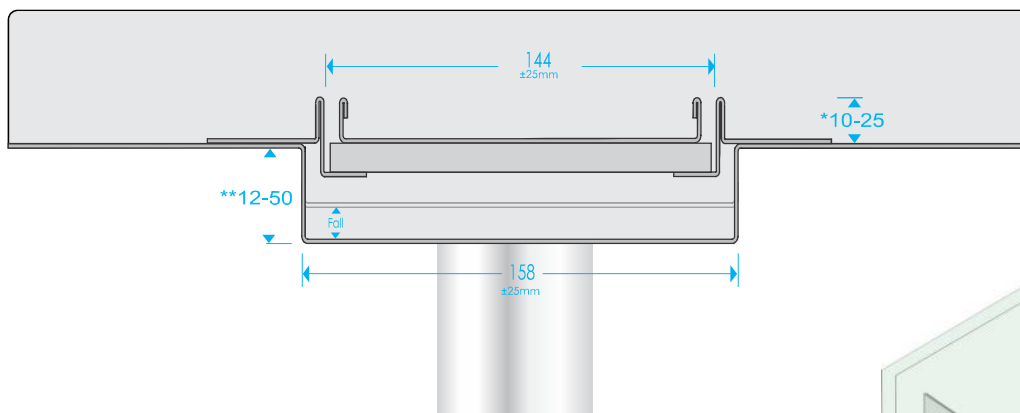

Please note waste droppers should be placed in door openings to allow for easy access

316

- Manufactured exclusively from 316 Stainless Steel (Marine Grade)
- Durable, Corrosive Resistant, Tensile Strength.

All dimensions are in millimetres, +/- 3.  
Drains 1.2mm Stainless Steel

Disclaimer: These drawings are the intellectual property of Creative Drain Solutions. This information is indicative only. Creative Drain Solutions accepts no liability arising from the use of this information.