

Advantage Series

Tile to Tile - Tile Insert Tray with Internal Glass

TITT - IG



Creative Drain Solutions™

R3 - 01.07.2020

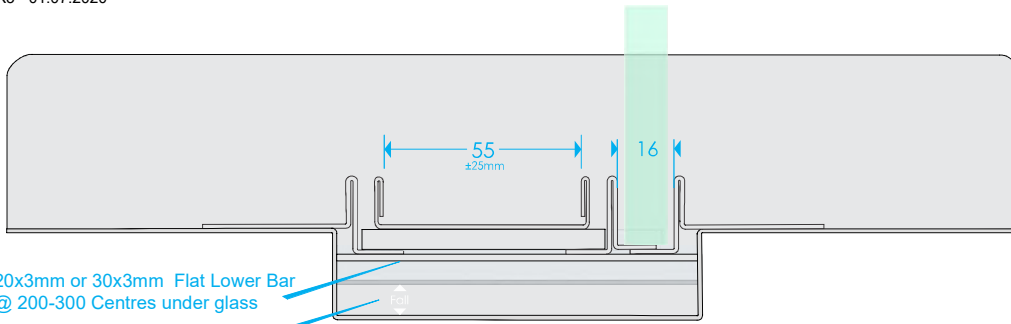

20x3mm or 30x3mm Flat Lower Bar @ 200-300 Centres under glass

Built in fall to waste outlet available

*Tile retention lips can be adjusted to suit your specific tile thickness. (13mm shown for 10mm tile thickness)
 **drain depth can be adjusted to suit, min. 12mm, max. 50mm.

Available in lengths between 800mm - 7000mm

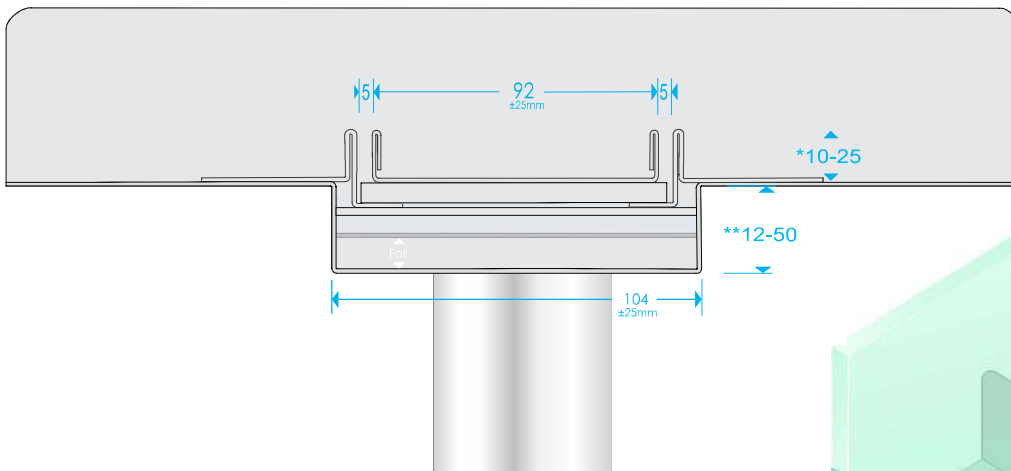

Glass screen (by others)

HF Channel (Optional - Not fixed to drain)

Removable Tile Insert Trays

Fixing Points

Glazing channel

Punched slot weep holes to allow for water ingress to escape from under tile

Custom Outlet to suit your requirements

Note: Outlets should be placed in doorways for easy access

316

- Manufactured exclusively from 316 Stainless Steel (Marine Grade)
- Durable, Corrosive Resistant, Tensile Strength.

All dimensions are in millimetres, +/- 3.
 Drains 1.2mm Stainless Steel

Disclaimer: These drawings are the intellectual property of Creative Drain Solutions. This information is indicative only. Creative Drain Solutions accepts no liability arising from the use of this information.